

Operation manual

Cooling thermostat

LP 8

Manufacturer:

LAUDA DR. R. WOBSEER GMBH & CO. KG

Laudaplatz 1

97922 Lauda-Königshofen

Germany

Telephone: +49 (0)9343 503-0

E-mail: info@lauda.de

Internet: <https://www.lauda.de>

Translation of the original operation manual

Q4DA-E_13-043, 1, en_US ©LAUDA 2025

03/20/2026

Table of contents

1	Safety.....	5
1.1	General Information.....	5
1.2	Intended use.....	5
1.3	Obligations of the operator.....	6
1.4	Prohibition of modifications to the device.....	6
1.5	EMC requirements.....	6
1.6	Materials.....	7
1.7	Natural refrigerant.....	7
1.8	Heat transfer liquid requirements.....	7
1.9	Hose requirements.....	7
1.10	Environmental and operating conditions.....	8
1.11	Time limits.....	8
1.12	Warranty conditions.....	8
1.13	Copyright.....	8
1.14	Contact DKSH.....	9
1.15	Safety features on the device.....	9
1.16	Structure of the warnings.....	9
1.17	Personnel qualification.....	10
1.18	Personal protective equipment.....	11
2	Unpacking.....	12
3	Device description.....	13
3.1	Structure of cooling thermostat.....	13
3.2	Operating elements.....	15
3.3	Designation of device types.....	16
3.4	Components in contact with media.....	16
3.5	Cooling unit.....	16
4	Before starting up.....	18
4.1	Install device.....	18
4.2	Hoses.....	21
4.3	Heat transfer liquids.....	22
5	Commissioning.....	24
5.1	Establishing a mains connection.....	24
5.2	Filling the device.....	25
5.3	Switching on the device.....	26
5.4	Menu structure.....	27
5.5	Setting the set temperature – <i>SEt</i>	28
5.6	Setting the temperature limits – <i>Hi</i> and <i>Lo</i>	28

6	Operation.....	30
6.1	Safety instructions prior to operation.....	30
6.2	Setting the timer – <i>ASd</i>	32
6.3	Setting the cooling unit’s operating mode – <i>Cool</i>	33
6.4	Entering the offset of the internal temperature probe – <i>CAL</i>	33
6.5	Restoring the factory settings – <i>dEF</i>	34
6.6	Standby – <i>StbY</i>	35
7	Maintenance.....	36
7.1	Maintenance safety instructions.....	36
7.2	Maintenance intervals.....	37
7.3	Cleaning the air-cooled condenser.....	37
7.4	Check the heat transfer liquid.....	38
7.5	Check excess temperature and low-level protection device.....	40
7.6	Resetting the SAFE excess temperature alarm.....	40
7.7	Pump motor monitoring.....	41
8	Faults.....	42
8.1	Alarms and error messages.....	42
8.2	Overview of error messages.....	43
9	Decommissioning.....	44
9.1	Changing/draining the heat transfer liquid.....	44
10	Disposal.....	46
10.1	Disposing of refrigerant.....	46
10.2	Device disposal.....	46
10.3	Disposing of packaging.....	46
11	Technical data.....	47
11.1	General technical data.....	47
11.2	Cooling thermostats.....	47
11.3	Current consumption and heating output.....	48
11.4	Cooling capacity.....	49
11.5	Refrigerant and filling charge.....	49
11.6	Cooling curve.....	50
11.7	Pump characteristics.....	50
12	Declaration of Conformity.....	51
13	Index.....	52

1 Safety

1.1 General Information

Operating manual



IMPORTANT READ CAREFULLY BEFORE USE KEEP FOR FUTURE REFERENCE

- Read this operating manual carefully before use.
- All personnel must have read and understood the operating instructions before operating the device.
- Follow all the warnings and safety instructions on the device and in the operating manual.
- Always keep the operating manual within easy reach near the device.
- This operating manual is part of the device. Never pass the device on to third parties without the operating manual.
- The device must always be operated as intended according to the instructions in this operating manual. Any other use is considered to be unintended use. The manufacturer assumes no liability or guarantee for improper use.

Safe state

"Safe state" is understood to have the following meaning:

- It is the operating state of a system in which the risk to people, the environment or equipment is minimal.

The constant temperature equipment switches to the "safe state":

- in the event of overtemperature,
- if the liquid falls below the specified minimum level
- or if one or more errors or alarms occur.

The "safe state" is indicated by:

- Heating off
- Pump off
- Visual signal
- Acoustic signal

1.2 Intended use

The devices can only be operated as intended under the conditions specified in this operating manual. Any other use is considered improper. It is the operator's responsibility to ensure that the devices are used properly.

Intended use

This device may only be used for controlling the temperature of non-flammable heat transfer liquids.

A heating and cooling thermostat is used for controlling the temperature of liquids in a bath vessel, and for controlling the temperature and circulating liquids in an external circuit.

A heating thermostat is used for heating heat transfer liquids in a bath vessel and for heating and circulating heat transfer liquids in an external circuit. The heating thermostat can be operated with a cooling coil. In this case, the heating thermostat can also be used to cool heat transfer liquids.

Reasonably foreseeable improper use

The following are considered cases of reasonably foreseeable misuse:

- Operating the device without heat transfer liquid
- Operating the device with a flammable heat transfer liquid
- Operating the device with an unsuitable heat transfer liquid
- Operating the pump and control unit without a bath unit or suspension device
- Medical applications
- Use in potentially explosive atmospheres
- Used for controlling the temperature of foodstuffs
- Outdoor installation
- Operation with an open consumer
- Operation with cables that are faulty, unsuitable or do not conform to standards
- Operation with faulty or unsuitable hoses
- Operation with the pump and control unit placed on the bath in a twisted position

The residual risks are described in the warnings and safety instructions in this operating manual.

1.3 Obligations of the operator

Observe the national regulations for operating the system in the country in which the system is installed.

In particular, the application of statutory regulations concerning operational safety must be observed.

1.4 Prohibition of modifications to the device

Any technical modification of the device by the user is prohibited. Any damage resulting from unauthorized modification is not covered by customer service or the product warranty. Service work may only be performed by the LAUDA Service department or a service partner authorized by LAUDA .

1.5 EMC requirements

Classification in accordance with EMC requirements DIN EN 61326-1			
Device	Requirements regarding immunity	Emissions class	Customer power supply
LP 8 cooling thermostats	Table 1 according to DIN EN 61326-1	Emissions class B according to CISPR 11	Only for EU Domestic connection value ≥ 100 A
	Table 1 according to DIN EN 61326-1	Emissions class B according to CISPR 11	the rest of the world No limitation

1.6 Materials

All parts of the device that come into contact with heat transfer liquid are manufactured from high-quality materials adapted to withstand the operating temperature. High-quality stainless steels and high-quality, temperature-resistant plastics are used.

1.7 Natural refrigerant



The devices are filled with natural refrigerant.

The devices with natural refrigerant are permanently sealed systems, containing less than 0.15 kg of refrigerant from safety group A3. These refrigerants are highly flammable. Due to the low filling charge and permanently sealed design, there are no special installation requirements.

The application area is only classified from a filling weight of over 0.15 kg, depending on the installation location and the requirements for using the space.

1.8 Heat transfer liquid requirements

The device is designed for non-flammable heat transfer liquids according to class division NFL as per DIN 12876.

- Heat transfer liquids are used to control the temperature.
- Heat transfer liquids from LAUDA are recommended. LAUDA heat transfer liquids are transfer liquids that have been tested and approved by LAUDA DR. R. WOBSE GMBH & CO. KG.
- All possible risks in handling the heat transfer liquid are specified in the safety data sheet for the liquid together with corresponding safety measures. The safety data sheet of the heat transfer liquid must therefore be observed to ensure proper use of the device.
- The heat transfer liquids are suitable for a specific temperature range. Select a heat transfer liquid with a temperature range suitable for the application.
- If you wish to use your own heat transfer liquids, you must check that the liquids are suitable for the materials used.
The heat transfer liquid must be provided with corrosion protection. You must also test the suitability of the heat transfer liquid by performing a test run within the desired temperature range. During the test run, you must also check the low level protection.

1.9 Hose requirements

The

- temperature,
- pressure and
- media resistance of the hoses must be suitable for the respective application.

Refer to for information on recommended hoses.

1.10 Environmental and operating conditions

The device may only be used in the following areas:

- Production, quality assurance, research and development in an industrial environment
- Only used inside buildings
- Use up to a height of 2,000 m above sea level
- Ambient temperature from 5°C to 40°C
- Maximum relative humidity 80% at temperatures up to 31°C, linearly decreasing up to 50% relative humidity at 40°C
- Mains voltage fluctuations, see ↪ Chapter 11.1 “General technical data” on page 47
- Transient electrical surges up to the values of surge category II
- Sporadic electric surges that occur in the mains power supply
- Pollution degree 2

1.11 Time limits

- | | |
|-----------------------|--|
| Service life | - All devices are designed for continuous operation. |
| Service life | - The device is designed for 20,000 operating hours. |
| Maintenance intervals | - ↪ Chapter 7.2 “Maintenance intervals” on page 37 |

1.12 Warranty conditions

LAUDA grants a standard warranty of one year.

1.13 Copyright

This operating manual was written in German, checked and approved. If the content of other language editions deviates from the German edition, the information in the German edition shall take precedence. If you notice any discrepancies in the content, please contact LAUDA Service, see .

Company and product names mentioned in the operating manual are usually registered trademarks of the respective companies and are therefore subject to brand and patent protection. Some of the images used may also show accessories that are not included in the delivery.

All rights reserved, including those relating to technical modifications and translations. This operating manual or parts thereof may not be modified, translated or used in any other capacity without the written consent of LAUDA . Violation of this may obligate the violator to the payment of damages. Other claims reserved.

1.14 Contact DKSH

Contact the DKSH Service department in the following cases:

- Troubleshooting
- Technical questions
- Ordering accessories and spare parts

Please contact our sales department for questions relating to your specific application.

Contact information

DKSH Service

Email: labproinfo@dksh.com





1.15 Safety features on the device

Excess temperature protection

The device features an excess temperature and low level protection device that turns off the heating and the pump independently of the temperature controller. The switch-off point of the excess temperature protection is permanently configured to a value of 105°C and cannot be modified.

If the bath temperature exceeds the excess temperature protection, or the fill level of the heat transfer liquid is too low, an alarm is triggered. In the process, all safety-related components on the device are switched off on all poles.

1.16 Structure of the warnings

Warning signs	Type of danger
	Warning – dangerous electrical voltage.
	Warning – flammable substances.
	Warning – hot surface.
	Warning – slip hazard.
	Warning – danger zone.

Signal word	Meaning
DANGER!	This combination of symbol and signal word indicates an imminently dangerous situation that will result in death or serious injury if it is not avoided.
WARNING!	This combination of symbol and signal word indicates a potentially dangerous situation that can result in death or serious injury if it is not avoided.
CAUTION!	This combination of symbol and signal word indicates a possible dangerous situation that can result in minor injury if it is not avoided.
NOTICE!	This combination of symbol and signal word indicates a potentially dangerous situation that can result in material and environmental damage if it is not avoided.

	NOTICE! Origin of the hazard
	Possible consequences of the hazard
	<ul style="list-style-type: none"> ● Measure 1 ● Measure...

1.17 Personnel qualification

Certified specialist

Specialist who is certified and authorized to perform specific work.

Operating personnel

Operating personnel are personnel who have been instructed by qualified personnel on how use the device as intended in line with the information in the operating manual.

Specialized personnel

Certain activities on the device must be performed by specialized personnel. Specialized personnel are people whose professional education, knowledge, and experience as well as knowledge of relevant standards qualify them to assess the function and risks associated with the device and its use.

1.18 Personal protective equipment



Protective gloves

Protective gloves must be worn for certain tasks. The protective gloves must comply with standard DIN EN ISO 374-1. The protective gloves must be chemically resistant.



Protective work clothing

Protective clothing must be worn for certain tasks. This protective clothing must meet the legal requirements for personal protective equipment. Protective clothing with long sleeves must be worn. Additionally safety shoes are required.



Safety glasses

Safety glasses must be worn for certain tasks. The safety glasses must comply with the standard DIN EN 166. The glasses must be tightly closed and equipped with side plates.

2 Unpacking

Personnel: Operating personnel



WARNING!
Leaks in the cooling circuit due to transport damage

Fire

- If you notice any damage to the transport packaging, store the device either in a well-ventilated place with no sources of ignition or outdoors. Contact LAUDA Service.

- Wear protective gloves when unpacking.
 - Use the handles on the front and rear of the bath unit to lift and carry the unit.
1. Unpack the device.
 2. Check that the device is complete and free of transport damage immediately after delivery.

Standard accessories

Part number	Quantity	Designation
Q4WA-E_13-004-DE	1x	Operating manual
---	2x	Flow rate reducer with different hole diameters (Ø 4.5 mm or 6.0 mm) for the pump outlet
---	1x	Bath cover
---	1x	Pump connector kit
---	1x	Silicone pump link (for connecting the outflow to the outlet)
EZB 260		Warning sticker "Hot surface"

3 Device description

3.1 Structure of cooling thermostat

Front view

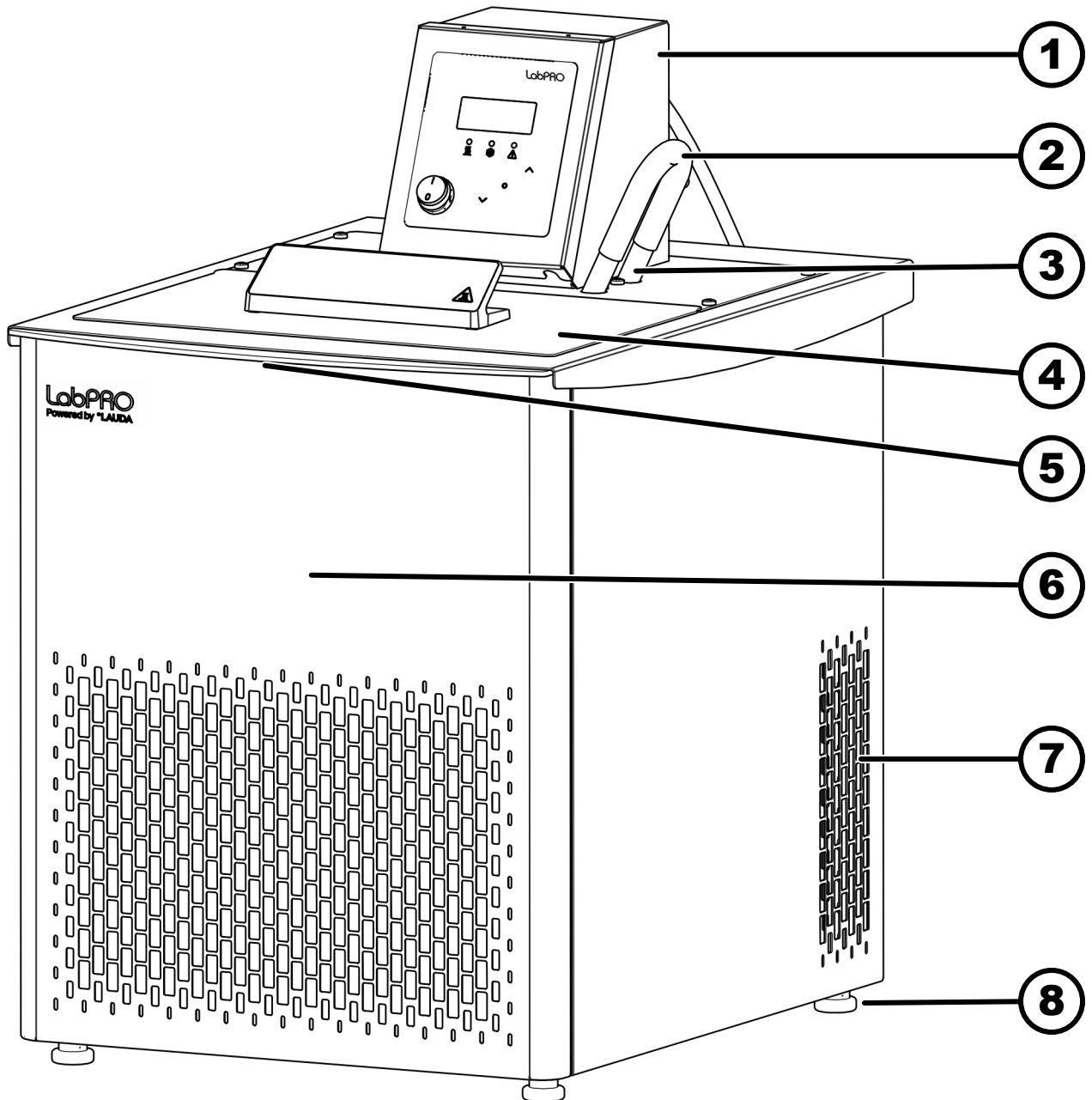

Fig. 1: Cooling thermostat, front view

- | | | | |
|---|---|---|--------------------------------|
| 1 | Pump and control unit | 5 | Handle on the front |
| 2 | Pump link (standard accessories) | 6 | Front panel (detachable) |
| 3 | Pump connectors (inlet on left and outlet on right) | 7 | Ventilation grid on both sides |
| 4 | Bath cover | 8 | Four feet |

Rear view

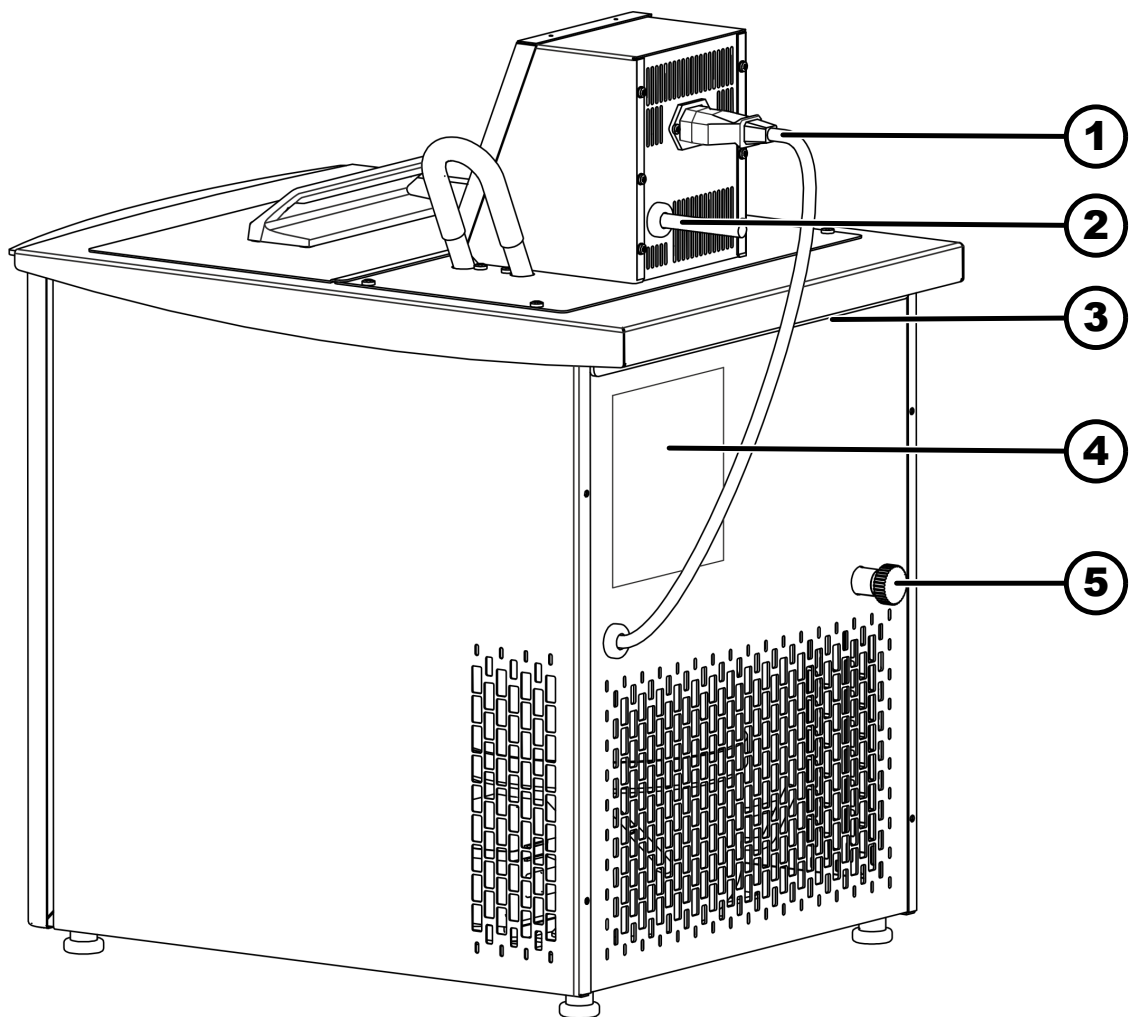

Fig. 2: Cooling thermostat, rear view

- 1 Power supply connection cable for cold bath
- 2 Power supply line
- 3 Recessed grip at the rear
- 4 Type plate
- 5 Bath draining nozzle

3.2 Operating elements

Control panel

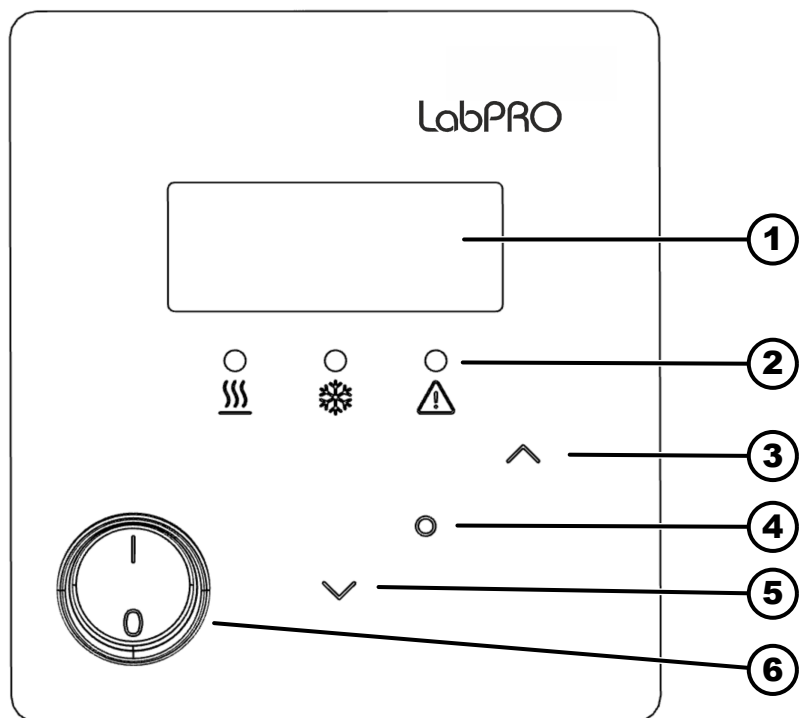





Fig. 3: Control panel

- 1 Display (7-segment)
- 2 Signal LEDs
- 3 Up arrow key, for settings and menu navigation
- 4 Enter key
- 5 Down arrow key, for settings and menu navigation
- 6 Mains switch

Signal LEDs

The signal LEDs on the control panel indicate the following operating statuses:

-  Yellow LED - Heating is active
-  Blue LED - Cooling is active
-  Red LED - Fault (LED flashes)

Operating buttons

The buttons can be used to control the following functions on the device display:

With the Enter key:

- Change from the current bath temperature display to the menu.
- Select menu items and confirm settings.



Most settings are automatically applied after the Enter key has not been pressed for approx. four seconds.

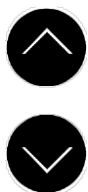

- Change from the standby status (*StbY*) to the menu after timer shut-down.
- Reset error messages and change to the menu.

With the Up and Down arrow buttons:

- Navigate through the device menu.
- Change settings and numerical values.
Input can be accelerated by continuously holding down the buttons.
- In the event of error messages, change to the bath temperature display.

Mains switch

The device is fitted with a mains switch. Position [0] switches the device off, position [1] switches it on.

3.3 Designation of device types

The type designations of cooling thermostats are composed of the letters LP (LabPRO) and the bath volume of the refrigeration unit in liters.

Example:

- LP 8 = Pump and control unit plus refrigeration unit with a maximum bath volume of 8 liters.

3.4 Components in contact with media

Bath boiler

Stainless steel bath boiler for filling with heat transfer liquid, for cooling thermostats with integrated tube coil evaporator.

Pump

- The pump in the pump and control unit circulates the heat transfer liquid inside the bath boiler. This achieves a homogeneous temperature distribution.
- The pump operates at a set speed. The pump volume flow can be reduced with the aid of a flow rate reducer. The flow rate reducer prevents the heat transfer liquid from overflowing in small baths.
- The pump's discharge nozzle can be closed without disturbing the pump.
- During operation without a (silicone) pump link, the heat transfer liquid can be circulated via the pump connector in an external application.

Heating

Heating of pump and control unit to heat up the heat transfer liquid.

3.5 Cooling unit



The cooling unit contains natural refrigerant, which is flammable.

The cooling unit consists of the following main components:

■ **Compressor**

The compressor is fully hermetically encapsulated and has a set speed. During operation, the compressor switches on automatically but can also be activated manually via the control menu. If safety-related faults occur, the compressor is switched off automatically.

■ **Evaporator**

A stainless steel tube coil evaporator extracts the heat from the heat transfer liquid in the internal bath.

■ **Pressure relief mechanism**

The pressure relief mechanism is implemented by means of a capillary tube. The capillary tube limits the refrigerant flow rate and, before it enters the evaporator, converts it from a heated liquid at high pressure into a cooled liquid at low pressure.

■ **Condenser**

Condensation heat and motor heat is dissipated by a fan-cooled fin condenser. This involves fresh air being drawn in at the front of the device and then the heated air being discharged at the rear and sides. To ensure smooth air circulation and heat discharge, the ventilation openings must not be blocked.

4 Before starting up

4.1 Install device



Each cooling circuit of LP 8 cooling thermostats contains less than 150 g of flammable refrigerant.

- According to standard EN 378-1, permanently sealed refrigeration systems below this filling limit are not subject to any special requirements regarding installation location, room volume or access area.



DANGER!

Contact with voltage conductors due to faulty power supply cable

Electric shock

- Check the supplied power supply cable for damage prior to use.



WARNING!

Distribution box / multiple socket is unsuitable

Fire

- Only connect the device directly to the socket on the installation side.
- Do not use distribution boxes or multiple sockets.



WARNING!

Danger of the device rolling away or overturning

Impact, crushing

- Do not tilt the device!
- Position the device on an even, non-slip surface with a sufficient load carrying capacity!
- Do not position the device close to table edges.



WARNING!

Danger of overpressure if ambient temperature is too high

Injury, escape of refrigerant, fire

- Note the permissible ambient temperature and storage temperature.



WARNING!
Risk of heat transfer liquid leaking

Scalding, cold burns

- Do not store any liquids or objects above the device.



WARNING!
Risk of heat transfer liquid leaking

Scalding, cold burns

- The temperature and media resistance of the hoses must be suitable for the application.
- Use hoses with a greater compressive strength than the maximum possible pump pressure. For liquids with a density above 1 kg/dm^3 , the pump pressure must be converted according to the density.
- Use pressure-resistant external applications or safety valves in the hydraulic circuit.
- When laying the hoses for the application, make sure that the hoses cannot be kinked or crushed.
- Always secure the hoses with suitable hose safety devices.



WARNING!
Contact with hot or cold hoses

Hot and cold burns

- Use insulated hoses for temperatures below $0 \text{ }^\circ\text{C}$ and above $70 \text{ }^\circ\text{C}$.



WARNING!
Risk of heat transfer liquid escaping during operation with an open consuming unit

Scalding, cold burns

- Always use hydraulically sealed consuming units.



WARNING!
Bursting of the external consuming unit due to excessive pressure

Scalding, cold burns

- If the external consuming unit is located in a lower position and is sensitive to pressure, also take into account the additional pressure resulting from the difference in height between the consuming unit and the device.
- For pressure-sensitive consuming units (for example, glass apparatus) with a maximum permissible operating pressure below the maximum pressure of the pump (see Technical Data section), the hoses of the consuming unit must be laid in such a way that bending or squeezing is not possible.
- A separate safety valve must be installed in the outflow to protect against operating errors.



WARNING!
Use of unsuitable heat transfer liquid

Fire, mutation, poisoning, environmental hazard, equipment damage

- Heat transfer liquids from LAUDA are recommended.
- If you wish to use your own heat transfer liquids, you must check that the liquids are suitable for the materials used. The heat transfer liquid must be provided with corrosion protection. You must also test the suitability of the liquid by performing a test run within the desired temperature range. During the test run, you must also check the low-level protection.
- Select a heat transfer liquid with a temperature range suitable for the application.
- Only ever use non-flammable heat transfer liquids.
- Do not use any heat transfer liquids that are radioactive, toxic or environmentally hazardous.
- Do not use deionized water as a heat transfer liquid.
- Only use heat transfer liquids that are approved for heat transfer systems.
- Do not use heat transfer liquids with a kinematic viscosity above $75 \text{ mm}^2/\text{s}$ during regular operation.
- Use heat transfer liquids with a density in the range of 0.95 to 1.2 g/cm^3 .

- Personnel: ■ Specialized personnel
- Protective equipment: ■ Protective work clothing
■ Safety glasses
■ Protective gloves

Connecting an external application

1. Please note the following:
 - When connecting the hoses:
 - Remove the (silicone) pump link from the outflow and outlet of the pump connector.
 - Secure the hoses with hose clamps on the outflow and outlet of the pump connector.
 - Use the shortest possible hoses with the largest possible diameter. If the diameter of the hose is too small or too long, the temperature will drop between the constant temperature equipment and the external application due to the low flow rate.
 - If the application is positioned higher than the constant temperature equipment, the following can happen:
 - Air can enter the external fluid circuit when the pump is not in operation,
 - which can allow liquid to flow from the application into the constant temperature equipment even though the circuit is sealed,
 - resulting in the liquid in the constant temperature equipment overflowing.

Disconnecting an external application

2. If the constant temperature equipment is disconnected from the external application,
 - the outflow and outlet of the pump connector at the constant temperature equipment must be connected with a pump link,

4.2 Hoses

Approved elastomer hoses

Hose type	Clear Ø in mm	Outer diameter in mm	Temperature range of the hose in °C	Application area	Part number
EPDM hose, not insulated	9	13	10 – 90	for all LAUDA heat transfer liquids approved for the LP 8 thermostat	RKJ 111
EPDM hose, not insulated	12	16	10 – 90	for all LAUDA heat transfer liquids approved for the LP 8 thermostat	RKJ 112
EPDM hose, insulated	12	35	-35 – 90	for all LAUDA heat transfer liquids approved for the LP 8 thermostat	LZS 021
Silicone hose, not insulated	11	15	10 – 100	Water, water-glycol mixture	RKJ 059
Silicone tube, insulated	11	33	-60 – 100	Water, water-glycol mixture	LZS 007

4.3 Heat transfer liquids

Please note:

- If the heat transfer liquid reaches the lower limit of the temperature range, the temperature control properties can be expected to deteriorate as a result of the increase in viscosity. Therefore, only fully utilize this temperature range when absolutely necessary.
- Never use contaminated heat transfer liquids. Contamination in the pump housing can cause the pump to seize and the device to shut down.
- Observe the safety data sheet for the heat transfer liquid. You can request a copy of the safety data sheets at any time, if necessary.

Table 1: Approved heat transfer liquids

Designation	Chemical name	Working temperature range in °C	Viscosity (kin) in mm ² /s (at 20 °C)	Viscosity (kin) in mm ² /s at temperature	Flash point in °C
Aqua 90	Decalcified water	5–90	1	---	---
Kryo 10	Water-propylene glycol mixture	-10 – 90	4.3	14 at -10 °C	---
Kryo 15	Water/monoethylene glycol mixture	-20 – 90	2.62	17.63 at -20°C	---
Kryo 30	Water/monoethylene glycol mixture	-30 – 90	4	50 at -25 °C	---

- When using Kryo 30, Kryo 15 and Kryo 10:
The water content decreases during longer periods of operation at higher temperatures, and the mixture becomes flammable.
The flash point of the glycol used in the heat transfer liquid:
 - Monoethylene glycol (Kryo 30, Kryo 15): 119°C
 - Propylene glycol (Kryo 10): 104°C
 Check the mixing ratio using a hydrometer, for example.
- Evaporation losses occur at higher temperatures. In this case, use a bath cover.

Table 2: Heat transfer liquid part numbers

Designation	Container size			
	Part number			
	5 L	10 L	20 L	200 L
Aqua 90	LZB 120	LZB 220	LZB 320	---
Kryo 10	LZB 132	LZB 232	LZB 332	LZB 832
Kryo 15	LZB 133	LZB 233	LZB 333	LZB 833
Kryo 30	LZB 109	LZB 209	LZB 309	LZB 809

Heat transfer liquid, water

- The proportion of alkaline earth ions in the water must be between 0.71 mmol/L and 1.42 mmol/L (equivalent of 4.0 °dH and 8.0 °dH). Harder water leaves limescale deposits in the device.
- The pH value of the water must be between 6.0 and 8.5.
- Distilled, deionized and demineralized water are unsuitable due to their reactivity. High-purity water and distillates are suitable as a heat transfer liquid after 0.1 g of soda (Na_2CO_3 , sodium carbonate) is added for every liter of water.
- Sea water is unsuitable due to its corrosive properties.
- Avoid chlorine in the water at all costs. Do not add chlorine to the water. Cleaning agents and disinfectants, for example, contain chlorine.
- The water must be free of impurities. Water with iron content is unsuitable due to rust formation and untreated river water is unsuitable due to algae growth.
- The addition of ammonia is not permitted.

5 Commissioning

5.1 Establishing a mains connection



DANGER!
Transport damage

Electric shock

- Closely inspect the device for transport damage prior to starting up.
- Never operate a device that has sustained transport damage!



DANGER!
Contact with voltage conductors due to faulty power supply cable

Electric shock

- The power supply cable must not come into contact with hoses containing heat transfer liquid or other hot parts.



NOTICE!
Use of impermissible mains voltage or mains frequency

Device damage

- Compare the type plate with the available mains voltage and mains frequency.

Note on the power supply for cooling thermostats:

- Before connecting a device to the mains power, always compare the mains voltage and mains frequency with the type plate on the pump and control unit and with the type plate on the cold bath.
- The pump and control unit supplies power to the cold bath. Connect the cable for the cold bath's power supply to the pump and control unit.

Note for electric installation on site:

- The devices must be protected by a circuit breaker with a rated current not exceeding 16 amps.
 - Exception: For devices with a UK plug, the rated current is limited to a maximum of 13 amps.
- For information about the device's maximum current consumption, refer to the type plate of the pump and control unit.

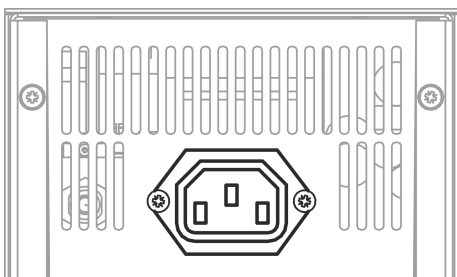

Fig. 4: Socket for the cold bath connection

Please note:

- The mains plug on the device is the primary component for disconnecting from the power supply.
 - The mains plug must be easy to identify.
 - The mains plug must be easy to access.
 - It must be easy to pull the mains plug out of the socket.
- Always use standard power supply cables such as the one supplied.
- Connect the device to a socket with a protective earth conductor (PE).

5.2 Filling the device

LAUDA is not liable for damages resulting from the use of unsuitable heat transfer liquids. You can find approved heat transfer liquids in .



DANGER!
Spraying of heat transfer liquid

Electric shock

- Do not spray heat transfer liquid.



WARNING!
Splashing heat transfer liquid

Eye damage

- Always wear suitable safety glasses when working on the device.



CAUTION!
Overflow of heat transfer liquid

Slipping or falling over

- Do not overfill the device.



CAUTION!
Risk of heat transfer liquid leaking

Slipping or falling over

- Drain tap must be closed.
- Ensure that all hydraulic connections are tight.



CAUTION!
Risk of heat transfer liquid leaking from incorrectly sealed pump connections

Scalding, cold burns

- Attach a pump link to the pump connections if an external consuming unit is not connected.



Heat transfer liquids expand when heated (approx. 10% for every 100°C). If an external consuming unit is connected, expansion occurs exclusively in the thermostat bath.

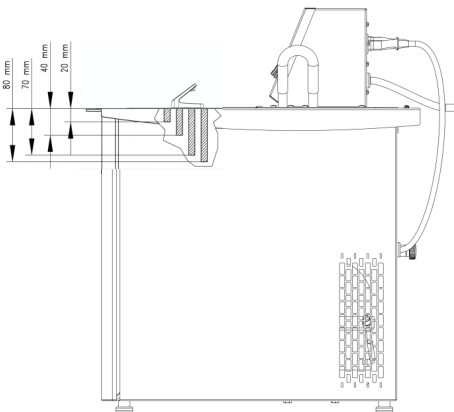

1. Make sure that the bath draining nozzle is closed.
2. Carefully fill the bath with heat transfer liquid.



- Fill the bath up to a maximum fill level of 20 mm beneath the bath bridge.
- Optimal operation is achieved at a fill level of 20 to 40 mm beneath the bath bridge.
- Operation is possible with a fill level of 70 mm beneath the bath bridge. The heating, pump housing and return connector must be covered with liquid.
- Low liquid level switch-off occurs at approx. 80 mm beneath the bath bridge.

5.3 Switching on the device



DANGER!
Formation of condensation (after transport)

Electric shock

- After transporting the device, wait for at least 24 hours, before putting it into operation to allow the device to adapt to the temperature at the installation location.



1 s

1. Switch on the device at the mains switch.
 - ▶ A beep is sounded for about one second.
 - ▶ The device performs a self-test. All display elements and symbols appear for about one second.
 - ▶ The current bath temperature is displayed.

5.4 Menu structure

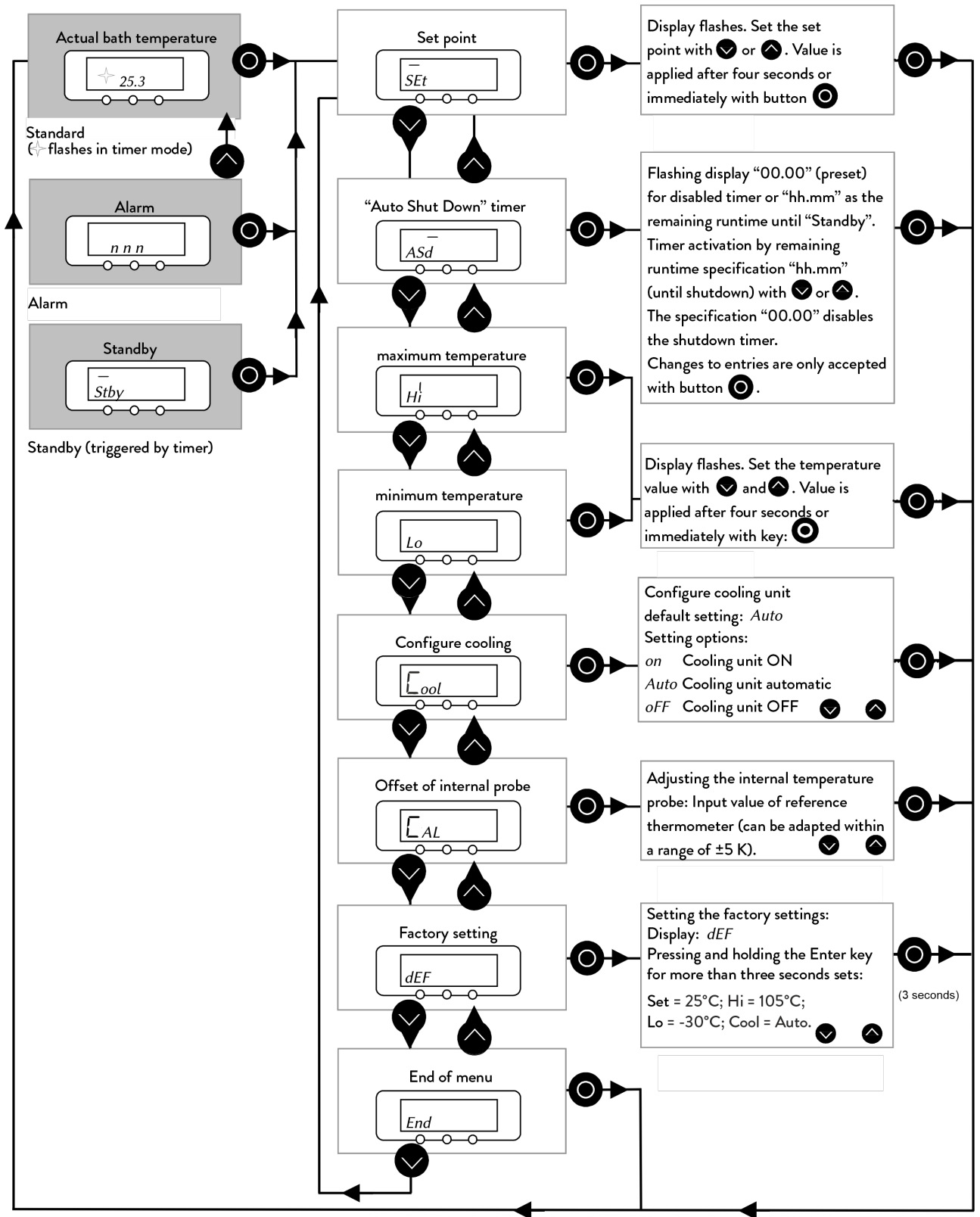
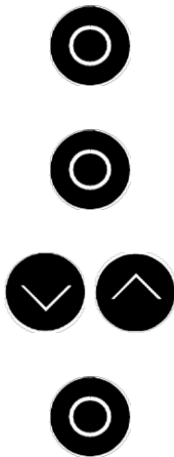

Fig. 5: Menu structure

5.5 Setting the set temperature – *SEt*



The set temperature is the temperature at which the thermostat should constantly keep the heat transfer liquid in the bath.

1. Press the [Enter key] until **SEt** (Setpoint) is displayed
2. Press the [Enter key].
 - ▶ The currently set temperature flashes.
3. Select the required set temperature using the [arrow buttons].
4. Press the [Enter key] to apply the new value.



The new value is automatically applied after four seconds without pressing the Enter key.



If a short acoustic warning signal is emitted after the set point has been entered, this means that the set temperature is less than 5°C from the upper or lower temperature limit and has therefore not been applied. If necessary, adjust the [Hi] and [Lo] temperature limits.

5.6 Setting the temperature limits – *Hi* and *Lo*

This function is used to set the **Hi** and **Lo** temperature limits. The temperature limits restrict the temperature range for the set temperature **SEt**. This makes it possible to prevent entry of a set point that could damage the heat transfer liquid or the equipment.

If the temperature limits are reached, a warning is issued. For example, if water is used as the heat transfer liquid, 95°C is appropriate as the upper limit and 5°C as the lower limit. The factory settings are Hi = 105 °C and Lo = -30 °C.

The temperature limits should reflect the limits of your application. The working temperature range of the heat transfer liquid must also be taken into consideration when defining the temperature limits.



Upper temperature limit



1. Press the [Enter key] until **SEt** (Setpoint) is displayed
2. Press the [Down arrow key] twice to access the **Hi** (upper temperature limit) menu item.
3. Press the [Enter key].
 - ▶ The currently set limit flashes.



Lower temperature limit



4. Set the required limit using the [arrow buttons].

5. Press the [Enter key] to apply the new limit.



The new value is automatically applied after four seconds without pressing the Enter key.

6. Press the [Down arrow key] to access the **Lo** (lower temperature limit) menu item.

7. Press the [Enter key].

▶ The currently set limit flashes.

8. Set the required limit using the [arrow buttons].

9. Press the [Enter key] to apply the new limit.



The new value is automatically applied after four seconds without pressing the Enter key.

6 Operation

6.1 Safety instructions prior to operation

All work on the device



DANGER!

If the pump and control unit are positioned incorrectly on the bath, vapors will cause deposits to form on printed circuit boards.

Electric shock

- If vapors are generated above the heat transfer liquid, use a sealed cover on the bath, wherever possible. Vapors must be prevented from entering the pump and control unit.



DANGER!

If the pump and control unit are positioned incorrectly on the bath, the power supply cable will be exposed to high temperatures. Contact with live cables.

Electric shock

- Immersion of the power supply cable in the heat transfer liquid and contact between the power supply cable and hot surfaces (> 70 °C) must be avoided.



DANGER!

Risk of immersion thermostat falling into the bath

Electric shock

- Only operate immersion thermostats on circuits with a residual current device (RCD).
- Make sure that the immersion thermostat bracket is securely connected to the bath.
- Only use bath vessels that are stable enough to support the immersion thermostat and designed to withstand the intended operating temperatures.



WARNING!

Splashing heat transfer liquid

Eye damage

- Always wear suitable safety glasses when working on the device.



WARNING!
Risk of mechanical damage to refrigerant circuit

Burns, fire

- Do not use mechanical tools to accelerate de-icing.



WARNING!
Leaks in the cooling circuit

Burns, fire

- Do not use corrosive heat transfer liquids.



WARNING!
Operating errors, technical defect

Fire

- Disconnect the mains plug to safely disconnect from the mains power.



CAUTION!
Danger due to inaccessible mains switch

Scalding, cold burns

- Make sure that the mains plug is always easily accessible. It must be possible to quickly pull the mains plug out of the socket.



CAUTION!
Object falling into the bath splashes heat transfer liquid

Scalding, cold burns

- Do not place any objects on the pump and control unit.



CAUTION!
Contact with hot/cold surfaces

Hot and cold burns

- Never touch parts that are labeled with the warning symbol "Hot surface".



CAUTION!
Restrictions during operation or setup

Ergonomic impairment

- Position the LAUDA thermostats on a table, pedestal or the floor so that all operating elements (bath, connections, interfaces, display, keyboard) are easy to use.



CAUTION!
Contact with heat transfer liquid vapors

Breathing difficulties

- Use an extractor system.
- Use a bath cover wherever possible.

6.2 Setting the timer – ASd

An (ASd = Automatic Shut-Down) timer can be set in the constant temperature equipment in order to switch the constant temperature equipment to standby mode at a specific point in time. In standby mode, the pump, heating and cooling unit are disabled; the display shows *StbY*.

1. Press the [Enter key] until **SEt** (Setpoint) is displayed.
2. Press the [Down arrow key] to access the **ASd** menu item.
3. Press the [Enter key].
 - ▶ The display flashes and shows the remaining time until shut-down in hours and minutes. If **00 00** is displayed, the timer is disabled.
4. Set the required time in hours and minutes using the [arrow buttons].
5. Press the [Enter key] to apply the new value.



The entry must be confirmed with the [Enter key] within four seconds of the last change in value.

- ▶ The timer function is activated. A **flashing decimal point** on the display of the current bath temperature shows that the timer function is active.



Reading the timer



Setting the timer



Disabling the timer

The timer function can be disabled at any time by entering **00 00**.

6.3 Setting the cooling unit's operating mode – *Cool*

The cooling unit of the devices is operated in the [AUTO] standard setting. Depending on the temperature and operating status, the cooling unit is switched on or off automatically (recommended mode of operation). You can switch the cooling unit on or off permanently via the menu. In the case of sensitive control processes, control fluctuations can be prevented by automatically switching the cooling unit on or off.

When the [OFF] setting is selected, only temperatures above room temperature can be reached. Selecting the [ON] setting may result in increased energy consumption due to permanent operation of the cooling unit.

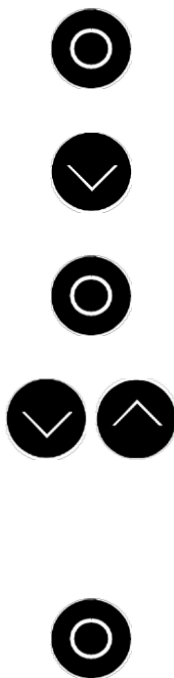

1. Press the [Enter key] until **SEt** (Setpoint) is displayed.
2. Press the [Down arrow key] to access the *Cool* menu item.
3. Press the [Enter key].
 - ▶ The display flashes.
4. Use the arrow keys to choose between the following operating modes:
 - [AUTO] - The cooling unit is switched on and off automatically as required.
 - [OFF] - The cooling unit remains permanently switched off.
 - [ON] - The cooling unit remains permanently switched on.
5. Press the [Enter key] to apply the new setting.



The new setting is automatically applied after four seconds without pressing the Enter key.

6.4 Entering the offset of the internal temperature probe – *CAL*

If a deviation is discovered during inspection with a calibrated reference thermometer, the offset value (i.e. the additive part of the characteristic line) of the internal measurement chain can be adjusted with the following function.

The reference thermometer must be immersed in the bath in accordance with the requirements of the calibration certificate. A reference thermometer with the desired degree of accuracy is required. Otherwise, the factory calibration should not be changed.



Please note:

The factory calibration is overwritten during the adjustment and cannot be restored.



1. Press the [Enter key] until **SEt** (Setpoint) is displayed.
2. Press the [Down arrow key] to access the **CAL** menu item.
3. Press and hold the [Enter key] for longer than three seconds.
 - ▶ The display flashes.
4. Set the value specified on the reference thermometer using the arrow buttons.
5. Press the [Enter key] to apply the value.



The new setting is automatically applied after four seconds without pressing the Enter key.

6.5 Restoring the factory settings – **dEF**

If you wish to restore all factory settings apart from the probe calibration, perform the reset as follows.



1. Press the [Enter key] until **SEt** (Setpoint) is displayed.
2. Press the [Down arrow key] to access the **dEF** menu item.
3. Press the [Enter key].
 - ▶ **dEF** flashes in the display.
4. Press and hold the [Enter key] for longer than three seconds (display briefly flickers).
 - ▶ Successful restoration of the factory settings is acknowledged with **donE** and the bath temperature is displayed again.

Factory setting values

Parameter	Description	Factory setting
SEt	Set temperature	25°C
Hi	Upper temperature limit	105°C

Parameter	Description	Factory setting
Lo	Lower temperature limit	-30°C
Cool	Cooling unit operating mode	Auto

6.6 Standby – *StbY*

Standby mode is entered following timer shut-down (see ↪ Chapter 6.2 “Setting the timer – *ASd*” on page 32. Press the Enter key to display the menu.



1. *StbY* is displayed. Press the [Enter key].

- ▶ The *SEt* menu item is displayed.



2. Press the [Down arrow key] several times to access the *End* menu item.



3. Press the [Enter key].

- ▶ The bath temperature is displayed.

7 Maintenance

7.1 Maintenance safety instructions



DANGER!
Contact with live or moving parts

Electric shock, impacts, cutting, crushing

- The device must be disconnected from the mains power supply before any kind of maintenance is performed.
- Only skilled personnel are permitted to perform repairs.



DANGER!
Risk of moisture/cleaning agent penetrating into the device

Electric shock

- Use a slightly damp cloth to clean the device.



WARNING!
Damage to surfaces during cleaning

Burning, fire, device damage

- Do not damage the cooling circuit.
- Do not use aggressive cleaners to clean the pump and control unit.
- Do not use chlorine-based cleaners for the bath vessel and evaporator.
- Do not use sharp or pointed objects to clean the evaporator.



WARNING!
A functional failure of the excess temperature and low-level protection is not detected

Burns, scalding, fire

- Check the excess temperature and low-level protection every time the heat transfer liquid is changed, and according to the defined maintenance intervals at the latest.



CAUTION!
Contact with hot / cold device parts, accessories and heat transfer liquid

Scalding, hot or cold burns

- Allow device parts, accessories and heat transfer liquid to reach room temperature before touching.

7.2 Maintenance intervals

Interval	Maintenance work
Before switching on the device	Check the power supply cable for damage
As required, once a month at the latest	(Visually) inspect the external hoses, tubing clips and screw connections for leaks and damage.
When filling for the first time, Every time the equipment has been transported, Every time the heat transfer liquid is changed, At least once a month	Check the excess temperature and low-level protection, see ↗ Chapter 7.5 “Check excess temperature and low-level protection device” on page 40.
As required, every three months at the latest	Clean the air-cooled condenser
As required, once every six months at the latest	Check that the heat transfer liquid is suitable for use
As required, once a year at the latest	Check the external condition of the device for damage and stability
Every twenty years	Replacement of safety-related electrical and electromechanical components by LAUDA Service, This includes the excess temperature and low-level protection.

7.3 Cleaning the air-cooled condenser



WARNING!
Risk of mechanical damage to refrigerant circuit

Burns, fire

- Do not damage the cooling circuit.
- Use suitable materials/tools to clean the condenser (e.g. soft brush, vacuum cleaner or compressed air). To do this, remove the detachable cover plate from the front of the device.



CAUTION!
Contact with sharp fins on the condenser

Cutting

- Wear protective gloves.

Removing the front panel

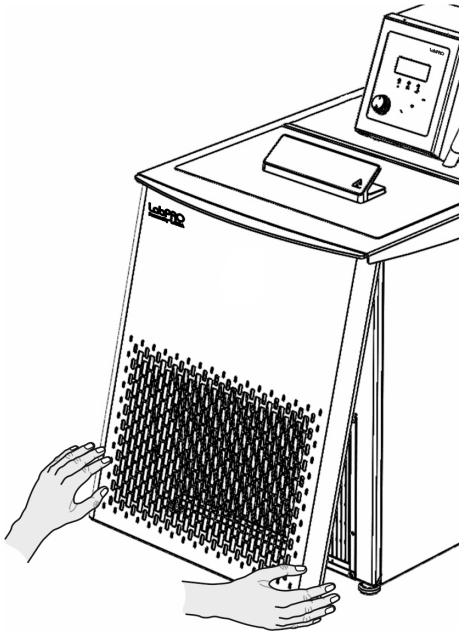

Fig. 6: Removing the front panel

1. Hold the front panel underneath at the sides and slide the front panel forwards.



The front panel is attached to the bottom of the chassis by two magnets.

2. Remove the front panel and clean the condenser.

Installing the front panel

1. Hold the front panel at the sides, tilt the top edge towards the device and place the front panel under the bath edge.
The two holes on the top edge of the front panel are fitted on the screws at the bottom of the bath edge.
2. Push the lower end of the front panel toward the bottom edge of the chassis.
 - ▶ The front panel is held in place by the two magnets on the underside of the chassis.
3. Check that the front panel is installed correctly by attempting to pull the bottom end of the front panel outward. The front panel should sit firmly.
 - ▶ You have installed the front panel correctly.

7.4 Check the heat transfer liquid



WARNING!

Contact with hot/cold heat transfer liquid

Scalding, cold burns

- Bring the heat transfer liquid to room temperature for analysis.

! **NOTICE!**
Wear, contamination, dilution of the heat transfer liquid

Device damage

- The serviceability of the heat transfer liquid must be checked if necessary (e.g. if the operating mode is changed) but at every prescribed maintenance interval at the latest.
Continued use of the heat transfer liquid is only permitted if the check indicates this.

i ***Wear of the heat transfer liquid***

- *Heat transfer liquid is subject to wear.*
- *The serviceability of the heat transfer liquid must be checked if necessary (e.g. if the operating mode is changed), at least every six months.*
- *Continued use of the heat transfer liquid is only permitted following successful testing.*

Protective equipment: ■ Safety glasses
■ Protective gloves
■ Protective work clothing

Where applicable, the following points should be considered when testing the heat transfer liquid:

- | | |
|---------------|--|
| Water content | 1. For water/monoethylene mixtures and water/propylene mixtures:
The water content decreases during longer periods of operation at higher temperatures and the mixture becomes flammable. |
| Cloudiness | 2. The water becomes opaque or cloudy due to micro-organisms, suspended matter and deposits. |
| Discoloration | 3. The liquid turns yellow, green or brown due to algae growth and bacterial decomposition processes |
| Odor | 4. The liquid emits a moldy musty odor due to bacteria and fungal growth. |
| Application | 5. General deterioration in thermal performance.
Reduction in the achievable temperature stability.
Clogging of hoses. |

7.5 Check excess temperature and low-level protection device

 WARNING! Contact with hot or cold heat transfer liquid	
Scalding, cold burns	
<ul style="list-style-type: none">Bring the heat transfer liquid to room temperature before draining.	

The check is carried out with a drained bath and the heating switched on. After a short while, the device should trigger an excess temperature alarm as soon as the safety temperature limiter switches on, due to the temperature being too high at the heater.

1. Set the temperature set point to 10°C.
2. Switch off the device.
3. Drain the bath.
4. Switch the device back on.
5. Set the temperature set point to the maximum possible value.

After 45 seconds at the latest, an excess temperature is triggered. The device switches to fault mode and the *SAFE* excess temperature alarm is displayed.



If, after 45 seconds, an excess temperature alarm is not triggered, shut down the device and contact LAUDA Service.



Fig. 7: Excess temperature alarm

6. Set the temperature set point to 10°C.
7. Switch off the device.
8. Pull the mains plug out of the power socket.
9. Wait 30 minutes until the heater has cooled down.
10. Reset the triggered safety temperature limiter, see [Chapter 7.6 “Resetting the SAFE excess temperature alarm”](#) on page 40.
 - ▶ You can now refill the device, put it back into operation and clear the alarm with the Enter key.

7.6 Resetting the SAFE excess temperature alarm

The excess temperature alarm is triggered by a safety temperature limiter (STL). The STL's sensor is attached at the device's heater. The STL has a permanently set switch-off point of 105°C. After being triggered due to excess temperature, the STL's snap-action switch must be manually reset.

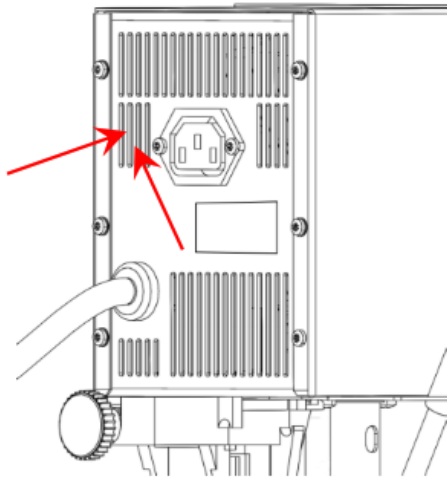
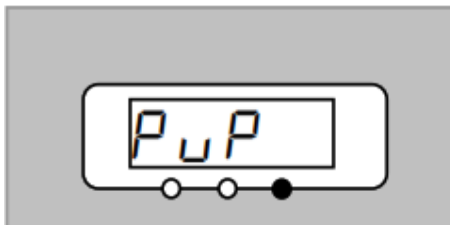

Fig. 8: Position of the button

7.7 Pump motor monitoring



1. Check the fill level in the bath and top up the heat transfer liquid, if necessary. The thermostat's heater must be completely covered with liquid.
2. Switch off the thermostat and pull out the mains plug from the socket.
3. To reset the excess temperature alarm, press the button on the STL behind the ventilation grid, for example with a ballpoint pen.
4. Switch the thermostats back on.

The pump motor is equipped with winding protection. In the event of overloading, the winding protection switches on and the *PuP* alarm is triggered. Causes could be, for example, too-high viscosity of the heat transfer liquid or a blocked pump.

1. Switch off the thermostat and pull out the mains plug from the socket.
2. Eliminate the cause of the pump motor overloading.
3. Switch the thermostats back on after waiting for a sufficient amount of time.
4. Press the Enter key.
5. Check the circulation in the bath during operation.
If the fault continues, contact LAUDA Service.

8 Faults

Troubleshooting/fault elimination and repair



DANGER!
Contact with live or moving parts

Electric shock

- Before starting any service or repair work, switch off the device and pull out the mains plug.
- Only skilled personnel are permitted to perform service and repair work.



DANGER!
Incorrect handling

Explosion, burns, fire

- Only certified specialists who are trained to handle flammable refrigerants are authorized to perform repair and disposal work.
- Any components and parts must be replaced with identical parts.

8.1 Alarms and error messages

The LP 8 thermostat triggers alarms or issues error messages if applicable. All error messages are displayed in the LED display.

The way the device behaves depends on the type of message and the user action required.

Alarms

Alarms affect safety. The device's components, such as the pump and heating, switch off. Alarms are indicated by the flashing red fault LED and two beeps. In addition, the alarm code appears on the display. Once the cause of the fault has been eliminated, the alarm can be acknowledged using the Enter key.

Error

In the event of an error, the components of the device, such as the pump and heating, switch off. Faults are indicated by the flashing red alarm LED and a double beep. In addition, the error code appears on the display.

You can clear error messages with the Enter key. If this happens, switch off the device at the mains switch. If the fault occurs again after switching on the device, make a note of the error code and contact LAUDA Service. You will find the contact information here .

8.2 Overview of error messages

Table 3: Alarms

Display	Description
ourt	Bath temperature is higher than the maximum permitted temperature 110°C.
hEAd	The temperature in the pump and control unit is higher than 75°C.
SAFE	Low level protection/excess temperature protection has triggered.
PuP	Pump motor monitoring has triggered.
Hi	Bath temperature is higher than the set upper temperature limit Hi.
Lo	Bath temperature is lower than the set lower temperature limit Lo.

Table 4: Error

Display	Description
E001	Short circuit at the bath temperature probe.
E002	Bath temperature probe broken.

9 Decommissioning

9.1 Changing/draining the heat transfer liquid



WARNING!
Contact with hot or cold heat transfer liquid

Scalding, cold burns

- Bring the heat transfer liquid to room temperature before draining.



WARNING!
Splashing heat transfer liquid

Eye damage

- Always wear suitable safety glasses when working on the device.



Observe the regulations for the disposal of used heat transfer liquid.

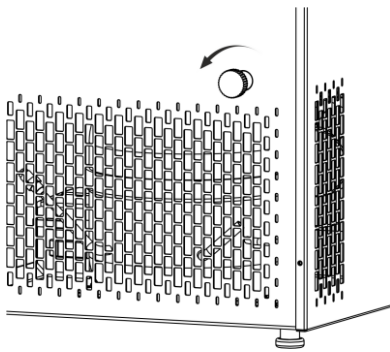

Fig. 9: Opening the bath draining nozzle

1. Allow the device and heat transfer liquid to cool or warm up to room temperature.
2. Turn off the device and pull out the mains plug.
3. Open the bath draining nozzle. Hold a suitable container under the draining nozzle.



Heat transfer liquid leaks out immediately on opening the bath draining nozzle. Quickly continue with the next steps.

4. Attach a hose to the draining nozzle. The hose must be closed at the other end.
5. Place the hose in a suitable container to collect the heat transfer liquid.



It may be necessary to drain the device several times if the filling volume is high.

6. Open the drainage hose.



Drain the bath, external consuming unit, accessories and hoses completely.

7. If necessary, clean or flush out the device (with new heat transfer liquid, for example).



After changing to a different heat transfer liquid, you may have to set new values for the temperature limits.

10 Disposal

10.1 Disposing of refrigerant



DANGER!
Uncontrolled leaking of refrigerant

Explosion, burns, fire

- Never dispose of a cooling circuit that is still pressurized.
- Only certified specialists who are trained in the handling of flammable refrigerants are permitted to perform disposal work.

Personnel: Certified specialist



The type and filling weight of the refrigerant are indicated on the type plate.

1. Always have any repair and disposal work carried out by a certified refrigeration technician.

10.2 Device disposal



The following applies for EU member states: The device must be disposed of according to Directive 2012/19/EU (WEEE Waste of Electrical and Electronic Equipment).

10.3 Disposing of packaging

The following applies for EU member states: Disposal of the packaging must proceed according to regulation 94/62/EC.

11 Technical data

11.1 General technical data

The information has been conveyed in accordance with DIN 12876.

Specification	Unit	Value
Installation and use	---	Indoors
Use up to a maximum height above sea level of	m	2000
Ambient temperature range	°C	5 – 40
Air humidity	%	Maximum relative humidity of 80% up to 31°C, and decreasing linearly to 50% up to 40°C
Storage temperature	°C	5 – 40
Transport temperature	°C	-20 – 43
Temperature stability at 37°C	K	±0.05
Display	---	7-segment LED display
Display and setting resolution	°C	0.1
Pump type/number of output levels	---	Pressure pump/1
Connections for consuming unit (accessories)	---	Hose nozzle nipples 1/2" (Ø 12.7 mm)
Class division according to DIN 12876	---	NFL*
Protection level of the casing according to DIN EN 60529	---	IP 20
Protection class for electrical equipment DIN EN 61140 (VDE 0140-1)	---	Protection class I according to DIN EN 61140; VDE 0140-1:2007-03

*NFL, non-flammable liquids only

11.2 Cooling thermostats

Table 5: Cooling thermostat LP 8 with natural refrigerant

Specification	Unit	LP 8
Working temperature range	°C	-25 – 100
Operating temperature range	°C	-25 – 100
Pump flow rate	l/min	15
Pump discharge pressure	bar	0.2
Filling volume - minimum	L	5

Specification	Unit	LP 8
- maximum	L	7.5
Bath boiler		Bath boiler made of deep-drawn stainless steel 1.4301 according to SAE 30304 AISI 304
Outer jacket (casing)		Powder-coated sheet steel
Feet		Four screw-on feet with rubber buffers
Bath opening (W x D) with control head	mm	165 x 177
Bath depth	mm	160
Usable bath depth	mm	140
Height of bath edge without cover	mm	450
Overall dimensions (W x D x H)	mm	235 x 500 x 605
Weight	kg	29
Clearance		
- Front	mm	400
- Rear	mm	400
- Right	mm	400
- Left	mm	400

11.3 Current consumption and heating output

Table 6: Cooling thermostat LP 8

Power supply	Current consumption in A	Power consumption in kW	Maximum heating output in kW
230 V; 50 Hz	12	1.8	1.5
115 V; 60 Hz	15	1.5	1.15
100 V; 50/60 Hz	15	1.3	1.0

11.4 Cooling capacity



The cooling capacity is measured when the heat transfer liquid reaches a certain temperature. The ambient temperature for the measurement is 20°C and ethanol is used as a heat transfer liquid.

Table 7: Cooling thermostat LP 8 with natural refrigerant

Cooling capacity at	Unit	LP 8
20°C	W	325
10°C	W	290
0°C	W	260
-10°C	W	180
-20°C	W	100
-25°C	W	70

11.5 Refrigerant and filling charge

Specification	Unit	LP 8
Natural refrigerant	---	R-290
Maximum filling weight	kg	0.052
GWP _(100a) *	---	3
CO ₂ equivalent	t	0.156



Global Warming Potential (GWP), CO₂ comparison = 1.0
*Time frame 100 years – according to IPCC IV

11.6 Cooling curve

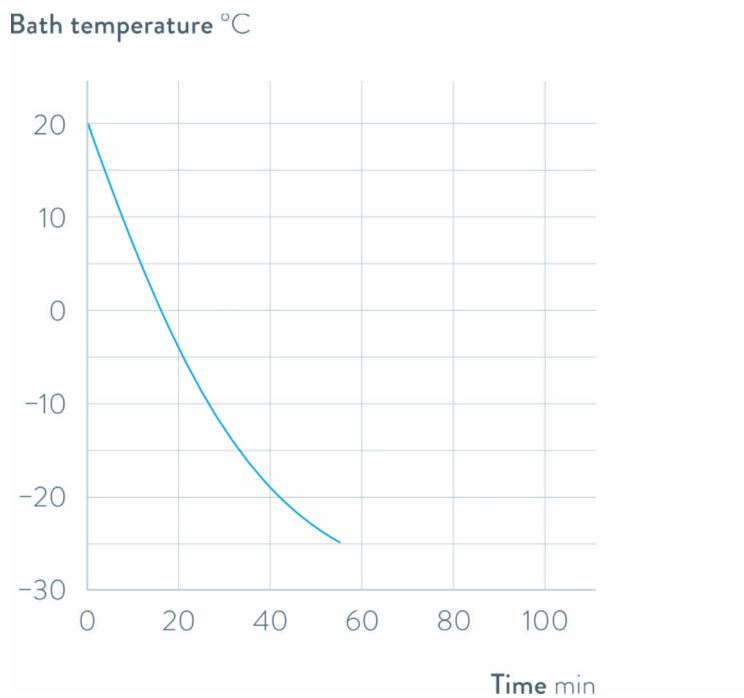

Fig. 10: Cooling curve LP 8

11.7 Pump characteristics

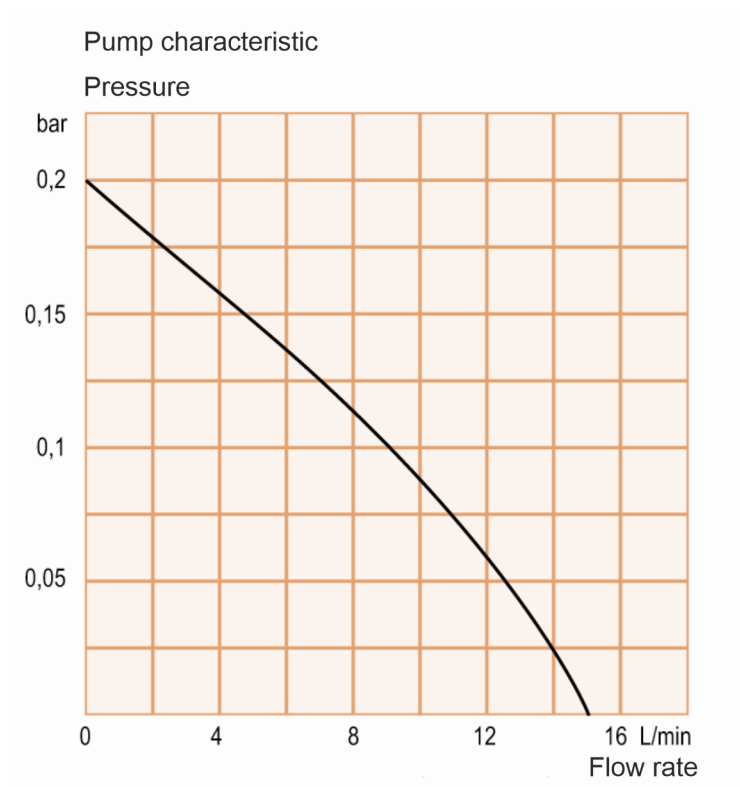

Fig. 11: Pump characteristic LP 8

12 Declaration of Conformity

Inhalt folgt

13 Index

A	
Accessories	
In series	12
Alarm	42
Description	42
Application	
connection	21
disconnection	21
Arrow buttons (position)	15
ASd	32
Automatic Shut-Down Timer	32
B	
Bath cover (illustration)	13
Bath draining nozzle (illustration)	14
C	
CAL	33
Check	
Excess temperature protection	40
Heat transfer liquid	38
Cleaning	
the condenser	37
CO ₂ equivalent	49
Consumer	
connection	21
Contact	9
Control panel buttons (illustration)	15
Cool	33
Cooling curve	50
Cooling function	
Setting the operating mode	33
Cooling unit	
Compressor	16
Condenser	16
Evaporator	16
Function	16
Pressure relief mechanism	16
Cooling unit operating mode	33
Copyright	8
D	
dEF	34
Device	
Disposal (packaging)	46
Disposal (refrigerant)	46
Draining	44
Filling	25
Device menu	27
DIN EN 378-1	7
Display buttons	
Operation	15
Disposal	
Packaging	46
Refrigerant	46
Disposing of refrigerant	46
Draining	
Device	44
E	
Error	42
Description	42
Establishing a mains connection	24
Establishing a power supply	24
Excess temperature protection	
Check	40
F	
Factory calibration	33
Factory setting	34
Fault	42
Feet (illustration)	13
Filling	25
Flushing	44
Front panel (illustration)	13
G	
GWP	49
H	
Handle	13

Heat transfer liquid		Standby	35
Check	38	StbY	35
Flushing	44	Structure	13
Hi	28	T	
I		Technical data	47
Input button (illustration)	15	Cooling curve	50
Intended use	5	Cooling thermostats	47
L		General	47
Limits	28	Pump characteristic	50
Lo	28	Refrigerant and filling charge	49
M		Timer	32
Mains switch	16	Type plate (position)	14
Maintenance		U	
Intervals	37	Unpacking	12
Maximum temperature	40	V	
Menu structure	27	Ventilation grid (illustration)	13
O		W	
Offset	33	Warranty	8
P			
Packaging			
Disposal	46		
Personal protective equipment (overview)	11		
Personnel qualification (overview)	10		
Protective equipment (personal, overview)	11		
Pump			
Connection (illustration)	13		
Pump characteristic	50		
R			
Refrigerant			
Flammable	7		
Refrigerant and filling charge	49		
Removing			
the front panel	37		
the heat transfer liquid	44		
S			
Service	9		
Set temperature	28		

Manufacturer:

Laudaplatz 1 ° 97922 Lauda-Königshofen ° Germany

Telephone: +49 (0)9343 503-0

E-mail: info@lauda.de ° Internet: <https://www.lauda.de>